

**REVIEW****X-ray computed tomography****Willi A Kalender**

Institute of Medical Physics, University Erlangen-Nuernberg, Henkestr. 91, D-91052 Erlangen, Germany

E-mail: [willi.kalender@imp.uni-erlangen.de](mailto:willi.kalender@imp.uni-erlangen.de)

Received 28 February 2006, in final form 4 April 2006

Published 20 June 2006

Online at [stacks.iop.org/PMB/51/R29](http://stacks.iop.org/PMB/51/R29)**Abstract**

X-ray computed tomography (CT), introduced into clinical practice in 1972, was the first of the modern slice-imaging modalities. To reconstruct images mathematically from measured data and to display and to archive them in digital form was a novelty then and is commonplace today. CT has shown a steady upward trend with respect to technology, performance and clinical use independent of predictions and expert assessments which forecast in the 1980s that it would be completely replaced by magnetic resonance imaging. CT not only survived but exhibited a true renaissance due to the introduction of spiral scanning which meant the transition from slice-by-slice imaging to true volume imaging. Complemented by the introduction of array detector technology in the 1990s, CT today allows imaging of whole organs or the whole body in 5 to 20 s with sub-millimetre isotropic resolution. This review of CT will proceed in chronological order focussing on technology, image quality and clinical applications. In its final part it will also briefly allude to novel uses of CT such as dual-source CT, C-arm flat-panel-detector CT and micro-CT. At present CT possibly exhibits a higher innovation rate than ever before. In consequence the topical and most recent developments will receive the greatest attention.

**1. Short historical introduction**

Computed tomography became feasible with the development of modern computer technology in the 1960s, but some of the ideas on which it is based can be traced back to the first half of that century. In 1917 the Bohemian mathematician Radon (1917) proved in a research paper of fundamental importance that the distribution of a material or material property in an object layer can be calculated if the integral values along any number of lines passing through the same layer are known. The first applications of this theory were developed for radioastronomy by Bracewell (1956), but they met with little response and were not exploited for medical purposes.

The first experiments on medical applications of this type of reconstructive tomography were carried out by the physicist A M Cormack, who worked on improving radiotherapy planning at Groote Schuur Hospital, Cape Town, South Africa. Between 1957 and 1963, and without knowledge of previous studies, he developed a method of calculating radiation absorption distributions in the human body based on transmission measurements (Cormack 1963). He postulated for radiological applications that it must be possible to display even the most minute absorption differences, i.e. different soft-tissue structures. However, he never had the chance of putting his theory into practice and only learned of Radon's work much later, a fact that he regretted by stating that earlier access to this knowledge would have saved him a lot of work. While familiarizing himself with Radon's work, Cormack discovered that Radon himself had been unaware of even earlier work on the subject by the Dutch physicist H A Lorentz, who had already proposed a solution of the mathematical problem for the three-dimensional (3D) case in 1905 (Cormack 1992).

While Cormack's work later was highly acknowledged as an essential contribution to the development of CT, there were others who deserve mention just the same. Oldendorf (1961) published his truly pioneering work in CT in 1961. Kuhl and Edwards (1963) introduced the concepts of emission computed tomography in 1963; although reconstruction efforts were limited to backprojection only, emission CT thus predated transmission CT. Filtered back projection was first described by Bracewell and Riddle (1967). Descriptions of algebraic reconstruction techniques were published by Gordon *et al* (1970) in 1970 and by Herman *et al* (1973), descriptions of Fourier reconstruction techniques by Bates and Peters (1971) in 1971. The key paper on the filtering functions necessary for CT reconstruction was the work of Shepp and Logan (1974).

The first successful practical implementation of the theory was achieved in 1972 by the English engineer G N Hounsfield, who is now generally recognized as the inventor of computed tomography (Hounsfield 1973). Like his predecessors, Hounsfield worked without knowledge of the earlier efforts. His success took the entire medical world by surprise. He achieved his remarkable breakthrough neither at a renowned university nor with a leading manufacturer of radiological equipment, but with the British firm EMI Ltd. His invention gave EMI, which had until then manufactured only records and electronic components, a monopoly in the CT market that lasted for two years, and the terms 'EMI Scanner' and 'CT Scanner' became almost synonymous (figure 1). In 1974 Siemens became the first traditional manufacturer of radiological equipment to market a head CT scanner, after which many other companies quickly followed suit. A boom followed, reaching its peak in the late seventies with 18 companies offering CT equipment. Most of these, including EMI, have withdrawn from the market by now.

The first clinical CT images were produced at the Atkinson Morley Hospital in London in 1972. The very first patient examination performed with CT offered convincing proof of the effectiveness of the method by detecting a cystic frontal lobe tumour. CT was immediately and enthusiastically welcomed by the medical community and has often been referred to as the most important invention in diagnostic radiology since the discovery of x-rays; its later development only confirmed these early expectations. Computed tomography has become a very important factor in radiological diagnosis. While only 60 EMI scanners had been installed by 1974, there were more than 10 000 devices in use in 1980, including a high number of head scanners. In 1979 Hounsfield and Cormack, an engineer and a physicist, were awarded the Nobel Prize for Medicine in recognition of their outstanding achievements.

At this point, the development seemed to have reached its peak, and the 1980s saw little technological progress. The introduction of spiral CT in 1989 (Kalender *et al* 1990b) and the

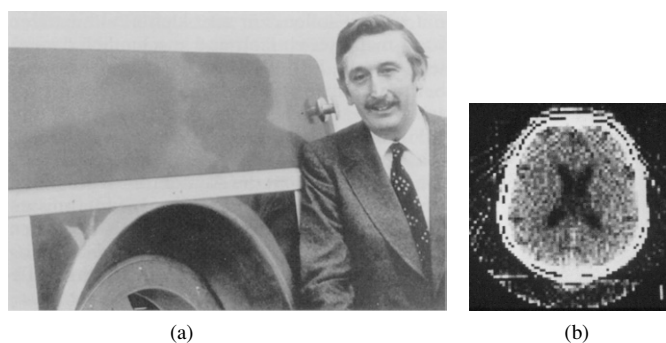

**Figure 1.** Godfrey N Hounsfield (a), an English engineer, developed the first CT scanner and, together with the physicist A M Cormack, received the Nobel Prize for Medicine and Physiology in 1979. Transverse slice imaging of the brain at low resolution with  $80 \times 80$  image matrices became the standard CT application in the first half of the 1970s (b).

following developments in x-ray, detector and scanner technology have led to a renewal of interest in CT and to a true renaissance of CT, as will be pointed out in detail below. For the year 2006, the number of clinical installations in operation is estimated to be about 45 000, almost exclusively whole-body spiral scanners. The upward trend is unbroken for the time being, and the position of CT in clinical radiology appears consolidated to a higher degree than ever before.

## 2. Developments in CT technology, performance characteristics and applications

The first clinical CT scanner allowed for the acquisition of single images in 300 s; today's scanners all feature rotation times below 1 s with the fastest ones offering 330 ms and effective image acquisition times down to the order of 100 ms for partial scans with dual-source systems. Among many other performance features which have improved steadily over the years, it appears that increasing scan speed always received highest priority and was the driving force behind CT developments. The basis of modern CT and its success is the fact that the increase in speed does apply not only to the acquisition of single images, but also to the acquisition of image data for complete volumes. Image quality, in particular 3D spatial resolution, the spectrum of clinical applications and many other factors have shown a steady improvement over the years just the same (table 1). The underlying technical developments can be assigned to a good approximation, although not strictly, to the single decades.

### 2.1. The 1970s—*from head to whole-body imaging*

The development of CT scanners began with Hounsfield's experimental set-up, which largely corresponded to the sketch in figure 2(a). This set-up was termed the 'first generation' of CT. The first commercial scanners, the so-called 'second generation', differed only little from Hounsfield's scanning system. To speed up scanning and to utilize the available x-ray power more efficiently detectors were added which entailed going from a pencil beam to a small fan beam. Both types of scanners functioned according to the translation–rotation principle in which the radiation source and the detector scan the object in a linear translatory motion and repeat this procedure successively after a small rotational increment (figures 2(a) and (b)). 180 projections were sampled in  $1^\circ$  steps with 160 data points each, i.e. a total of 28 800 data

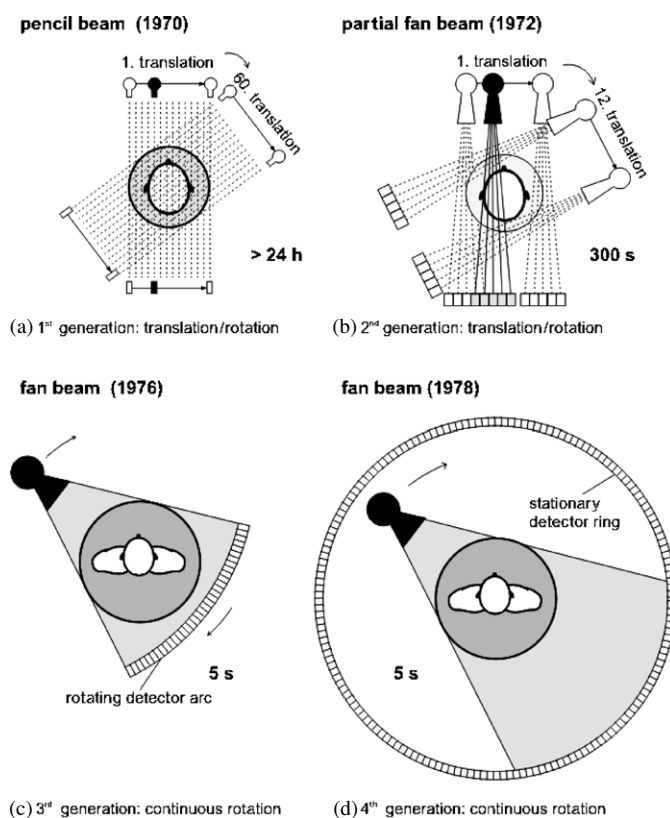

**Figure 2.** Four scanner generations were promoted in the 1970s. Head scanners, which scanned the patient by translation and rotation of the measurement system with a pencil beam (a) or a small fan beam (b), and fan beam systems, in which all body sections can be scanned with a continuous 360° rotation. The '3rd generation', featuring a rotating detector (c), has clearly outdistanced the '4th generation', which utilizes stationary detector rings (d).

**Table 1.** Performance characteristics<sup>a</sup> of CT in a comparison from 1972 to 2005. Significant improvements are given due to technological advances for almost all parameters. Contrast resolution reached a stable level since detector quantum efficiency was close to 100% early on.

	1972	1980	1990	2004	2005 (DSCT)
Rotation time (s)	300	5–10	1–2	0.33–0.5	0.33
Data per 360° scan (MB)	0.058	1	1–2	10–100	20–200
Data per spiral scan (MB)	–	–	24–48	200–4000	200–8000
Image matrix <sup>b</sup>	80 × 80	256 × 256	512 × 512	512 × 512	512 × 512
Power (kW)	2	10	40	60–100	2 × 80
Slice thickness, mm	13	2–10	1–10	0.5–1	0.5–1
Spatial resolution (LP cm <sup>-1</sup> )	3	8–12	10–15	12–25	12–25
Contrast resolution	5 mm/5 HU/ 50 mGy	3 mm/3 HU/ 30 mGy	3 mm/3 HU/ 30 mGy	3 mm/3 HU/ 30 mGy	3 mm/3 HU/ 30 mGy

<sup>a</sup> Typical values for high performance scanners.

<sup>b</sup> Values refer to the calculated matrix. Monitor displays often use 1024 × 1024 matrices by means of interpolation.

per scan. This was sufficient to calculate an image with 6400 pixels, i.e. an  $80 \times 80$  image matrix. Scan times were 5 min; image reconstruction was carried out simultaneously and took the same amount of time. Hounsfield reported an examination time of 35 min, in which the dual-row detector acquired  $6 \times 2$  images with 13 mm slice thickness. This constituted a remarkable performance. In the first trials in 1969 test objects were scanned by Hounsfield with an isotope source and required a scan time of 9 days per image.

Instead of sampling a transmission profile, i.e. a projection, by a pencil beam with translatory motion, a fan beam and a larger detector arc were used to measure a complete projection simultaneously (figures 2(c) and (d)). In this approach, the available x-ray power is again utilized more efficiently due to the larger solid angle subtended by the complete detector arc. The translatory motion became obsolete, and the systems executed a rotatory motion only. The first whole-body scanners with fan beam systems came to the market in 1976 providing scan times of 20 s per image. In the first scanners of this type both the x-ray tube and the detector rotated around the patient; the resulting scanner concept was termed 'third generation'. Only a little later scanners followed with a ring-like stationary detector fully encircling the patient so that only the x-ray tube rotated; it was termed the 'fourth generation'. Rotatory systems were quickly accepted, and translation-rotation systems meanwhile disappeared completely. The discussion of which type of rotation system is the superior one is over; the third generation has prevailed and constitutes the standard approach in clinical scanners today.

With the end of the decade CT was fully established. Scan times of 5 to 10 s per image and slice thicknesses of 5 and 10 mm were the standard. Even slip-ring scanners were proposed with a prototype being built by Varian; it did not reach product status though. A total of 18 manufacturers engaged in CT development during this period. A very good and comprehensive review of the state of the art in the 1970s was given in this journal at the time (Brooks 1976) and later in an excellent text book by this journal's editor (Webb 1990); a recent review of CT basics and its development from the first decade until today can be found in (Kalender 2005a).

## 2.2. The 1980s—fast scanning of single slices

It was obvious that image quality and therefore diagnostic capabilities depend strongly on scan time, since voluntary and involuntary patient motion will lead to losses of image sharpness and to artefacts. At the time, the necessary electrical energy was fed to the scanner's x-ray tube by cables. This prevented fast and continuous rotation, since the systems had to be accelerated in one direction, stopped after  $360^\circ$  and then accelerated again into the opposite direction. 'Fast scanners' of this type provided scan times down to 2 s in the 1980s.

The goal of providing shorter scan times was pursued in the 1980s in the form of many creative approaches; also academic research groups proposed and started work on several innovative concepts (Robb and Ritman 1979, Boyd 1981, Boyd and Lipton 1983). Two designs which made it into clinical practice are to be mentioned here: conventional CT systems with the possibility for continuous rotation and data acquisition and electron beam CT (EBCT) scanners which were designed primarily for cardiovascular applications. In EBCT an electron beam is swept across one of four semicircular targets which enclose the patient (figure 3). Since no mechanical motion is involved, scan times of 33 to 100 ms were provided and heart images of a quality remarkable for that time were achieved. Although some aspects of the EBCT concept appear very attractive further on, there are a number of decisive drawbacks. The focus trajectory is limited to a partial circle of typically  $220^\circ$ , i.e.  $180^\circ$  plus the fan angle, and to a plane which does not coincide with the plane of the detector arc of equally about  $220^\circ$  which necessarily has to be offset in the z-direction. Since the detector is stationary, no anti-scatter collimators can be used. Both disadvantages, the geometry and the lack of

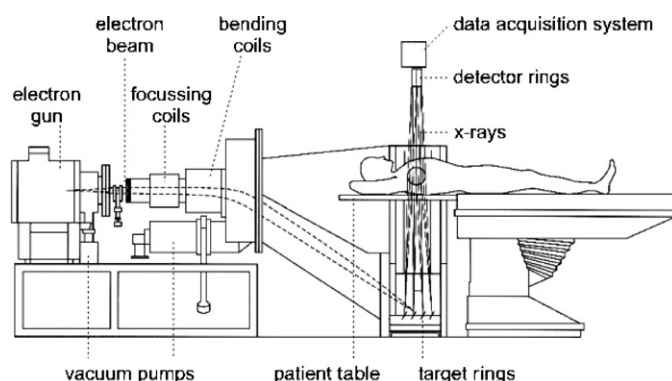

**Figure 3.** Many novel concepts for fast CT scanning were discussed since the late 1970s. Electron beam CT came to life and persisted for more than a decade. An electron beam is swept across a semicircular anode ring which encloses the patient. It permits single scans in the range of 30 to 100 ms without mechanical motion.

scatter collimators, also speak against the use of wider detector arrays. In addition, the x-ray power of the existing EBCT systems of typically 100 kW did not exceed the x-ray power of conventional systems significantly. In consequence it later turned out that spiral CT scanning with multi-row detectors provided higher image quality and higher volume scan speed at lower cost. EBCT persisted for less than two decades.

First efforts at using CT for quantification of tissue parameters, in particular for assessing tissue densities, had already started in the 1970s; bone density measurements were a primary goal (Adams *et al* 1982, Genant and Boyd 1977). Respective efforts were intensified in the 1980s. The development of a dedicated dual-energy CT product option for bone density measurements and its use in many hundreds of installations is one example (Kalender *et al* 1987). It is still used today with low-dose single-energy CT. The dual-energy option was discarded with the advent of faster scanning and the inherent change from pulsed to continuous data acquisition since the technical approach of rapid kV-switching from pulse to pulse became impossible.

Blood flow and perfusion measurements are a further example of quantitative CT. It started with measuring brain perfusion in minute intervals by assessing xenon accumulation in the brain (Gur *et al* 1989, Kalender *et al* 1991). With the advent of fast continuous CT measurement systems the approach of measuring the transit of a bolus of contrast medium injected into a peripheral vein during its passage through the tissue of interest was adopted. It is widely used today as a fast exam taking typically 30 s. Tissue perfusion maps, for example displays of brain perfusion in ml of blood per minute and gram of tissue, are used routinely in assessing patients with an acute brain infarction (König 2003).

Continuously rotating CT systems, based on 'slip-ring technology', were introduced in 1987. The electrical energy necessary for the x-ray tube is transferred by slip-rings instead of cables. Consequently, it was possible to abandon the start-stop type of operation (start for clockwise rotation – stop – start for counterclockwise rotation – stop – etc) and to replace it with continuous data acquisition. At the same time, rotation times were reduced to 1 s setting a new standard. The extension to continuous multi-rotation scanning resulted in decisive new impulses. It provided the basis for advanced dynamic examinations and finally for spiral CT. All CT scanners produced today make use of slip-ring technology and offer continuous rotation.

In spite of all these developments the 1980s cannot be considered as golden days of CT. Examinations slice by slice still took typically 20 to 40 min, a time unacceptably long in many cases. And the introduction of nuclear magnetic resonance imaging brought many experts to the conclusion that 'CT is dead'. The abbreviation 'NMR' was often interpreted as the mission statement 'No More Röntgen'. The manufacturers redirected research and development capacities from CT to MR in a massive way. I was personally given the recommendation by well-meaning friends multiple times to switch from CT to MR. The idea to develop fast volume scanning approaches for CT, but also other dedicated CT applications made it easy to stay. (Note that the N for 'nuclear' was omitted from NMR later, apparently because of general concerns regarding nuclear technology. It has remained open until today if the new abbreviation MR also implies the meaning 'More Röntgen'.)

### 2.3. The 1990s—from slice-by-slice imaging to spiral volume scanning

The first investigations and clinical trials of 'spiral CT' were already completed in 1989 and reported in four papers at the Annual Meeting of the Radiological Society of North America (Kalender *et al* 1989, Kalender *et al* 1990b). Although there are many valid reasons which can be quoted in retrospect for why spiral CT development appeared necessary, there clearly was one dominant single reason to go into the effort: clinical necessity. It was the endeavour to image anatomic structures, which are subject to motion, contiguously and reproducibly. Lung nodules are a primary example: to detect them with standard thick-slice techniques and to repeat the examination with thin slices for a morphometric analysis or to repeat the study after given time intervals to monitor their growth was a pending task. Respective efforts which I had planned and conducted together with Peter Vock, Bern, Switzerland, were not successful, simply because it was very hard to even find the nodule again, let alone image it reproducibly with a set of thin-slice images. Although we even worked under spirometric control (Kalender *et al* 1990a) and with cooperative patients, no truly contiguous image data sets were ever obtained.

Continuous scanning along the patient's longitudinal axis, which is the  $z$ -axis in the CT coordinate system, appeared to offer the solution. We implemented the first prototype by cheating on the scanner. While it assumed we were executing a multi-rotational dynamic CT scan of a selected slice for which slip-ring technology had primarily been designed, we abused a contrast medium power injector to push the patient table forward at a slow, but exactly controllable speed at one slice thickness per rotation, i.e. per second on the Siemens SOMATOM Plus scanner used. Relative to the patient the focus travelled on a spiral trajectory (figure 4(a)); albeit at a much lower image quality than today, it immediately allowed us the 3D assessment of lung nodules (figure 4(b)). (Note on terminology: spiral CT and helical CT are synonyms, just as spiral staircase and helical staircase. There is no right or wrong, yet the original term spiral is used more frequently (Kalender 1994)).

From today's perspective it appears only logical or even necessary to implement a spiral scan mode immediately together with the new slip-ring scanner technology. However, this was not the case at that time. The development and the introduction of continuously rotating scanners aimed at shorter scan times and at providing improved capabilities for dynamic CT. Spiral CT was not known yet. The first references to spiral CT can be found in several independent sources. A general patent on spiral scanning does not exist. My own patent request in 1988 was rejected with the statement that the combination of continuous data acquisition and continuous patient transport was already covered by the existing technique of taking survey radiographs and that reconstruction algorithms were not patentable. It took time, until the late 1990s, for the general consensus to develop that algorithms can be patented. A

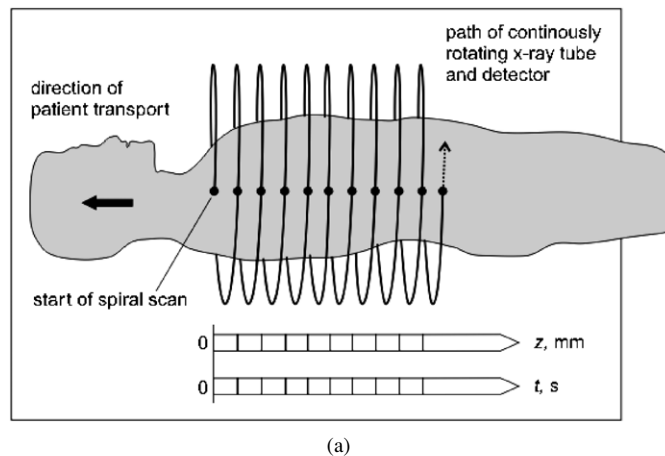

(a)



(b)

**Figure 4.** The introduction of slip-ring technology in the 1980s allowed for continuous data acquisition over many rotations and aimed at dynamic CT measurements. Transporting the patient through the gantry during the measurement results in a spiral focus trajectory (a). In 1989, although still limited in image quality (b), it meant the beginning of true, i.e. gapless volume scanning.

patent by Issei Mori (1986), the first reference to spiral CT in the patent literature, mentioned algorithms, but in fact specified electronic circuits in order to be able to define patent claims. These are hardly useful for the inventor anymore today, since hardware implementations would not be up-to-date and new algorithms are constantly under development. Results on spiral CT from Japan in the English language were first reported in 1993 (Toki 1993).

Parallel to these developments, although also without knowledge of the work carried out elsewhere, Y Bresler and C J Skrabacz of the University of Illinois carried out theoretical studies regarding the spiral scan principle, which were published relatively late (Bresler and Skrabacz 1993). They characterized their considerations as ‘intellectually interesting’, but of little relevance to practice. This assessment was reinforced by the American CT manufacturer GE Medical Systems, who also investigated this scan mode, but decided at the time that this



was not adequate for general clinical use due to problems which had to be expected with image quality (Crawford and King 1990).

The reasoning was that for sequential CT two basic requirements cannot be neglected without negative implications for image quality: the object to be scanned, i.e. the patient, may not move during data acquisition, and the scan geometry must be perfectly planar. The consequences are well known if one of these two conditions is violated. If the patient moves or if only inner organs or organ parts move during the scan, motion artefacts result. The same has to be expected if the patient, although cooperative and not moving, is being transported by table motion through the field of measurement. Examples of conflicts with the second requirement—strict adherence to planar scan geometry—were known just the same. Artefacts arise when the focus of the x-ray tube, due to thermal effects or mechanical inaccuracies, does not follow its prescribed path or when the focus and detector do not travel in the same plane. The latter problem exists in particular for EBCT scanners. In general and for the situations described above inconsistent data are generated, since the scanning system does not view exactly the same slice for different angular positions. Such inconsistencies lead to artefacts in the images. Spiral CT, however, builds precisely upon violating these two principles: it no longer requires the accepted planar geometry, and it moves the patient during scanning, in classical terms it thus constituted a sacrilege. This explains why most of the experts showed more than only minor reservations with respect to the new scan mode. Critics initially termed spiral CT ‘a method to produce artefacts in CT’. Alternatives were suggested, such as the use of moving collimators to combine the advantages of fast volume scanning and planar scan geometry (Toth *et al* 1991). The solution proposed in 1989 was the generation of data sets representing single slices from the spiral volume data set by data rebinning and z-interpolation (Kalender *et al* 1990b). It has proven successful since then and was also extended to multi-slice acquisition systems (Kachelrieß *et al* 2000a).

It took about three years for spiral CT to receive wider acceptance. At the end of 1992 all major CT manufacturers announced scanners with slip-ring technology and spiral CT capabilities. Since then an amazing technical development has been observed, providing huge increases in x-ray power, computer capacities and further technical improvements. But it was not only technical parameters and increased scan speed, it was the improvement of image quality: the potential for improved 3D resolution and lesion detection (Kalender *et al* 1994) and for isotropic sub-millimetre spatial resolution (Kalender 1995) provided by spiral CT was proven in the early 1990s.

These potentials became clinical reality with the introduction of four-slice CT systems and rotation times of 0.5 s in the year 1998. At the same time it meant a reduction of volume scan times by a factor of 8 compared with the typical 1 s systems with single-row detector, and it was the culmination of CT developments in the 1990s. Several dual-slice systems had been on the market earlier (table 2); the introduction of array detector technology in 1998 went significantly beyond this and meant the start of a series of new scanner developments. Adding more rows to the detector array was no problem once the technology had been mastered. Although the concepts and the number of detector rows differed considerably for the four manufacturers active in this field, amazingly they all arrived at providing four-slice acquisition in 1998 (table 2). It meant the start of the ‘slice race’ which became a phenomenon in the early 2000s. Wider detector arrays allow for faster scanning and for a more effective use of the available x-ray flux due to the increased solid angles.

The 1990s also meant the start of phase-selective cardiac imaging on conventional, i.e. non-EBCT scanners. First images were produced by Arkadiusz Polacin and Willi Kalender in the context of their work on new spiral reconstruction approaches (Polacin *et al* 1992). The reactions were similar to those regarding the proposal of spiral scanning. They met with

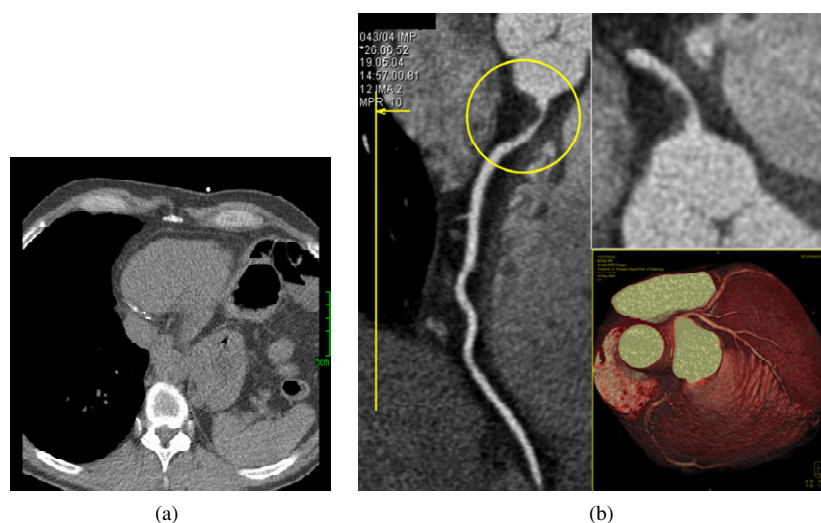
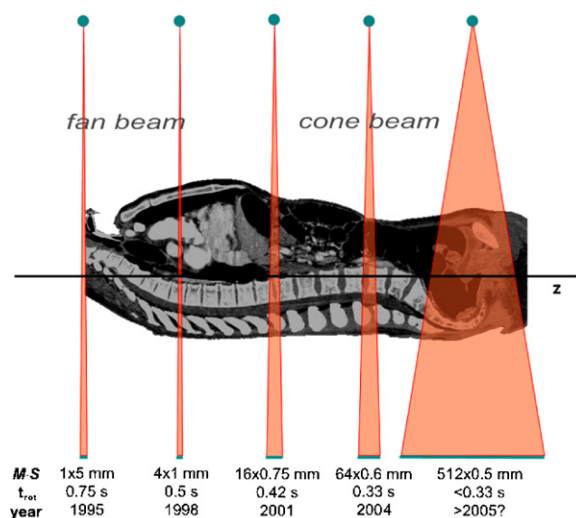

**Figure 5.** Spiral CT also provided the basis for phase-selective imaging of the heart. First efforts on single-slice scanners in the 1990s proved the principle (a), advanced solutions with 64-slice dual-source CT provide for fast and robust CT coronary angiography (b).

**Table 2.** CT scanners with multi-row detector systems.  $D$  represents the number of detector rows,  $M$  the number of simultaneously scanned slices.

Manufacturer	Scanner type	Number of rows $D$	Number of slices $M$	Year
EMI	Mark I	2	2	1972
Siemens	SIRETOM 2000	2	2	1974
Siemens	SOMATOM SD	2	2	1977
Imatron	C-100	2	2	1983
Elscent	Twin	2	2	1994
GE	LightSpeed	16	4	1998
Marconi	Mx8000	8	4	1998
Siemens	SOMATOM Volume Zoom	8	4	1998
Toshiba	Aquilion	34	4	1998
GE	LightSpeed 16	16	16	2001
Philips	IDT 16	24	16	2001
Siemens	SOMATOM Sensation 16	24	16	2001
Toshiba	Aquilion	40	16	2001
GE	VCT 64	64	64	2004
Philips	Brilliance 64	64	64	2004
Siemens	SOMATOM Sensation 64	40	64	2004
Toshiba	Aquilion 64	64	64	2004
Toshiba	prototype	256	256	2004
Siemens	SOMATOM Definition	$2 \times 40$	$2 \times 64$	2005

disbelief and were seen as undesirable since, in management terms, cardiac imaging was reserved for EBCT. It took until 1995 when the author became free to decide on projects—a situation which he always admired and envied Sir Godfrey Hounsfield for—that he resumed work on cardiac imaging. A number of publications followed (Kachelrieß and Kalender 1997, 1998, Kachelrieß *et al* 2000b), but it took until the early 2000s that the approach was included



**Figure 6.** The development from fan-beam to cone-beam CT was termed the ‘slice race’ in the early 2000s. It seems to come to a halt presently.

as product options by the manufacturers. Cardiac imaging and CT coronary angiography today are seen as striking advances in CT with very high clinical impact (figure 5).

With the end of the 1990s CT was fully re-established. Scan times of below 1 s per image and below 1 min for complete examinations were routinely available. And CT had become a topic of high scientific interest again, both for basic imaging and for radiological scientists. The modality CT, which had already been considered outdated in the eighties, experienced a ‘renaissance’ as was widely acknowledged.

#### 2.4. The 2000s—fast cone-beam scanning

The first years of the new millennium showed a direct continuation of the development trends of the previous decade: The ‘slice race’ picked up speed. More rows were added to the detector arrays and accordingly more slices were acquired simultaneously (figure 6). Simultaneous acquisition of 16 slices became available in 2001; 64-slice scanning represents the state of the art today and is provided equally by the four major manufacturers (table 2). Image quality has reached a very high level which can be guaranteed even at the short examination times; a few examples are compiled in figure 7 for illustration purposes, all obtained by scans of less than 15 s.

Nevertheless it was often postulated that the development would simply continue to 128, to 256 detector rows and so forth and that Moore’s law which predicts a doubling of computing power every 18 months in computer technology would also hold true for CT with respect to the number of slices scanned per unit time. There are clear limits, however, and a number of problems and disadvantages are to be expected if the cone angle is increased further (Kalender 2005b). So the question must be the following: why more slices?

Modern multi-slice CT scanners allow performing most of the desired examinations with very high reliability. One exception may be cardiac CT. Coronary CT angiography, for example, can be performed easily and non-invasively with 64-slice CT with scan times of less than 10 s with impressive results. However, the literature indicates a diagnostic success rate of about 80 to 90% only. Higher temporal resolution, i.e. shorter effective scan times

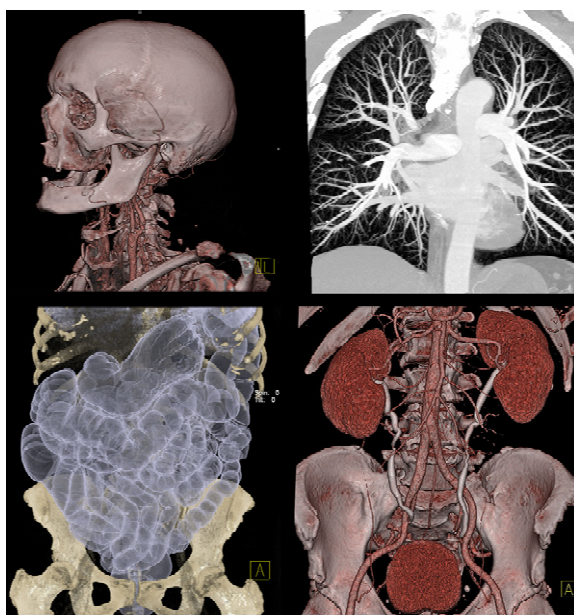

**Figure 7.** Modern multi-slice spiral CT covers virtually all body regions with sub-millimetre isotropic spatial resolution and scan times of 5 to 15 s.

were considered necessary in the early 2000s, and cardiac CT was the driving force for a new development.

Higher temporal resolution has always been achieved by higher rotation speed. There are severe obstacles, however, against continued increases in speed. It is not only the increase in centrifugal forces which have reached nearly 30 g on the typical scanners with 330 ms rotation time. It is above all the problem to provide the necessary x-ray power as image quality has to be kept at the required level. X-ray power has to be increased inversely proportional to the decrease in rotation time to arrive at a constant mAs product. It is not conceivable at present—and probably not either in the foreseeable future—how x-ray power levels of 200 kW or more can be provided to support rotation times below 200 ms.

An attractive alternative is multi-source systems, which were already discussed in the 1970s. A first scanner type with two x-ray units and two detectors became available in 2005 (Flohr *et al* 2006) and was installed at the Institute of Medical Physics in Erlangen (figure 8(a)). With a rotation time of 330 ms it provides effective scan times of 330/4 or 83 ms for partial scans. With phase-selective multi-segment reconstructions (Kachelrieß and Kalender 1998, Kachelrieß *et al* 2000b) this can be reduced further to 50 ms and less. Respective simulations showed that doubling the number of acquisition systems on a given gantry is a more efficient way to reduce effective scan times in cardiac imaging than a reduction of the rotation time by a factor of 2 (Kalender 2005b). The results of technical tests and of a first clinical evaluation confirmed expectations (Achenbach *et al* 2006). Cardiac imaging with CT now appears to have also reached a mature and stable level with the new dual-source CT (DSCT) technology (figure 8(b)).

What is left for CT to achieve in the future? The author expects further growth and refinements in all areas of CT, but decisive advances possibly outside the mainstream of clinical CT. Diversification in the use of CT, new contrast media and tracers, new combinations of

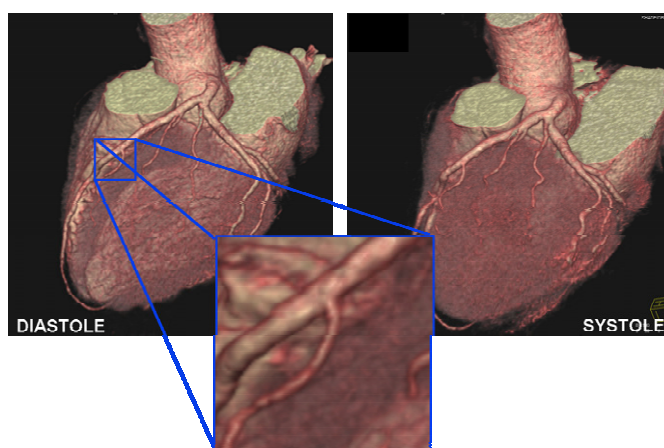
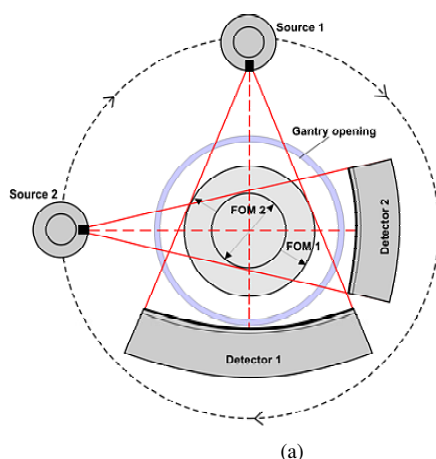

**Figure 8.** Dual-source CT assembles two complete x-ray and data acquisition systems on one gantry. The example shown, the SOMATOM Definition (Siemens Medical Solutions, Forchheim, Germany) which was introduced in 2005, employs two 80 kW systems at 330 ms rotation times (a) and provides effective scan times of 83 ms for cardiac imaging (b).

imaging modalities are of high interest. Wider detector arrays are considered for CT imaging in special applications. Respective efforts were already started in the 1990s (Fahrig *et al* 1997). Most important at present are the efforts to provide CT imaging on C-arm units for interventional and intra-operative imaging; it improves clinical workflow and will provide radiographic, fluoroscopic and CT imaging on one apparatus. Respective image reconstruction approaches are available (Pan *et al* 2004). It appears that standard clinical CT and C-arm interventional CT, which developed independently, may converge in several respects.

CT has never been mentioned in connection with molecular imaging concepts. However, it is already established in combination with positron and single-photon emission tomography (PET and SPECT) and in particular in pre-clinical research and small-animal imaging with micro-CT. The newly available DSCT technology offers practical means for dual-energy CT. In combination with new tracer developments this also offers new horizons for CT imaging.

CT is certainly still alive and appears to be in a more innovative phase in the early 2000s than it ever was before.

## Acknowledgments

Figures 1, 2 and 3 and a few short text passages on historical issues, slightly adapted, were taken from (Kalender 2005a) with friendly permission of the publisher.

## References

- Achenbach S *et al* 2006 Contrast-enhanced coronary artery visualization by dual-source computed tomography—initial experience *Eur. J. Radiol.* **57** 331–5
- Adams J, Chen S, Adams P and Isherwood I 1982 Measurement of trabecular bone mineral by dual energy computed tomography *J. Comput. Assist. Tomogr.* **6** 601–7
- Bates R H T and Peters T M 1971 Towards improvements in tomography *N. Z. J. Sci.* **14** 883–96
- Boyd D P 1981 Transmission computed tomography *Radiology of the Skull and Brain. Technical Aspects of Computed Tomography* vol 5, ed T Newton and D Potts (St Louis: CV Mosby Company) pp 4357–71
- Boyd D P and Lipton M J 1983 Cardiac computed tomography *Proc. IEEE* **71** 298–308
- Bracewell R N 1956 Strip integration in radioastronomy *J. Phys.* **9** 198–217
- Bracewell R N and Riddle A C 1967 Inversion of fan-beam scans in radion astronomy *Astrophys. J.* **150** 427–34
- Bresler Y and Skrabacz C 1993 Optimal interpolation in helical scan 3D computerized tomography *National Science Foundation (MIP 88–10412)* pp 1472–5
- Brooks R A 1976 Principles of computer assisted tomography (CAT) in radiographic and radioisotopic imaging *Phys. Med. Biol.* **21** 689–732
- Cormack A M 1963 Representation of a function by its line integrals, with some radiological applications *J. Appl. Phys.* **34** 2722–7
- Cormack A M 1992 75 years of radon transform *J. Comput. Assist. Tomogr.* **16** 673
- Crawford C and King K 1990 Computed tomography scanning with simultaneous patient translation *Med. Phys.* **17** 967–82
- Fahrig R, Fox S, Lownie S and Holdsworth D W 1997 Use of a C-arm system to generate true 3-D computed rotational angiograms: preliminary *in vitro* and *in vivo* results *Am. J. Neuroradiol.* **18** 1507–14
- Flohr T *et al* 2006 First performance of a dual-source CT (DSCT) system *Eur. Radiol.* **16** 256–68
- Genant H K and Boyd D 1977 Quantitative bone mineral analysis using dual energy computed tomography *Invest. Radiol.* **12** 545–51
- Gordon R, Bender R and Herman G T 1970 Algebraic reconstruction techniques (ART) for three-dimensional electron microscopy and x-ray photography *J. Theor. Biol.* **29** 471–82
- Gur D, Yonas H and Good W 1989 Local cerebral blood flow by xenon-enhanced CT: current status, potential improvements, and future directions *Cerebrovasc. Brain Metab. Rev.* **1** 68–86
- Herman G T, Lent A and Rowland S 1973 ART: Mathematics and applications (a report on the mathematical foundations and on the applicability to real data of the algebraic reconstruction techniques) *J. Theor. Biol.* **42** 1–32
- Hounsfield G N 1973 Computerized transverse axial scanning (tomography): I. Description of system *Br. J. Radiol.* **46** 1016
- Kachelrieß M and Kalender W A 1997 ECG-based phase-oriented reconstruction from subsecond spiral CT scans of the heart *Radiology* **205** 215
- Kachelrieß M and Kalender W A 1998 Electrocardiogram-correlated image reconstruction from subsecond spiral CT scans of the heart *Med. Phys.* **25** 2417–31
- Kachelrieß M, Schaller S and Kalender W A 2000a Advanced single-slice rebinning in cone-beam spiral CT *Med. Phys.* **27** 754–72
- Kachelrieß M, Ulzheimer S and Kalender W A 2000b ECG-correlated image reconstruction from subsecond multi-slice spiral CT scans of the heart *Med. Phys.* **27** 1881–902
- Kalender W A, Klotz E and Süß C 1987 An integral approach to vertebral bone mineral analysis by x-ray computed tomography *Radiology* **164** 419–23
- Kalender W A, Seissler W and Vock P 1989 Single-breath-hold spiral volumetric CT by continuous patient translation and scanner rotation *Radiology* **173** 414
- Kalender W A, Rienmüller R, Seißler W, Behr J, Welke M and Fichte H 1990a Spirometric gating for measuring pulmonary parenchymal density by quantitative computed tomography *Radiology* **175** 265–8
- Kalender W A, Seissler W, Klotz E and Vock P 1990b Spiral volumetric CT with single-breathhold technique, continuous transport, and continuous scanner rotation *Radiology* **176** 181–3

- Kalender W A, Polacin A, Eidloth H, Kashiwagi S, Yamashita T and Nakano S 1991 Brain perfusion studies by xenon-enhanced CT using washin/washout study protocols *J. Comput. Assist. Tomogr.* **15** 816–22
- Kalender W A 1994 Spiral or helical CT: right or wrong? *Radiology* **193** 583
- Kalender W A, Polacin A and Süß C 1994 A comparison of conventional and spiral CT: an experimental study on the detection of spherical lesions *J. Comput. Assist. Tomogr.* **18** 167–76
- Kalender W A 1995 Thin-section three-dimensional spiral CT: is isotropic imaging possible? *Radiology* **197** 578–80
- Kalender W A 2005a *Computed Tomography. Fundamentals, System Technology, Image Quality, Applications* (Erlangen: Publicis Corporate Publishing)
- Kalender W A 2005b CT: the unexpected evolution of an imaging modality *Eur. Radiol.* **15** D21–4
- König M 2003 Brain perfusion CT in acute stroke: current status *Eur. J. Radiol.* **45** S11–22
- Kuhl E and Edwards R Q 1963 Image separation radioisotope scanning *Radiology* **80** 653–61
- Mori I 1986 Computerized tomographic apparatus utilizing a radiation source *United States Patent Number Dec. 16, 4630202*
- Oldendorf W H 1961 Isolated flying spot detection of radiodensity discontinuities —displaying the internal structural patterns of a complex object *IRE Trans. Biomed. Electron.* **8** 68–72
- Pan X, Xia D, Zou Y and Yu L 2004 A unified analysis of FBP-based algorithms in helical cone-beam and circular cone- and fan-beam scans *Phys. Med. Biol.* **49** 4349–69
- Polacin A, Kalender W A and Marchal G 1992 Evaluation of section sensitivity profiles and image noise in spiral CT *Radiology* **185** 29–35
- Radon J H 1917 Über die Bestimmung von Funktionen durch ihre Integralwerte längs gewisser Mannigfaltigkeiten *Ber. vor Sächs. Akad. Wiss.* **69** 262
- Robb R and Ritman E L 1979 High speed synchronous volume computed tomography of the heart *Radiology* **133** 655–61
- Shepp L A and Logan B F 1974 The Fourier reconstruction of a head section *IEEE Trans. Nucl. Sci.* **21** 21–43
- Toki Y 1993 Principles of helical scanning *Basic Principles and Clinical Applications of Helical Scan: Application of Continuous-Rotation CT* ed K Kimura and S Koga (Tokyo: Iryokagakusha) pp 110–20
- Toth T, Crawford C and King K 1991 Moving beam helical scanning *Radiology* **181** 278
- Webb S 1990 *From the Watching of Shadows. The Origin of Radiological Tomography* (Bristol: IOPP)

## Biography



**Willi A Kalender** received his Master's Degree and PhD in Medical Physics from the University of Wisconsin, Madison, Wisconsin, USA in 1979. In 1988 he completed all postdoctoral lecturing qualifications (Habilitation) for Medical Physics at the University of Tübingen. From 1979 to 1995 he worked in the research laboratories of Siemens Medical Systems in Erlangen, Germany, from 1988 to 1995 as head of the Medical Physics division. Since 1991 he has been Adjunct Associate Professor of Medical Physics at the University of Wisconsin, from 1993 to 1995 he lectured at the Technical University of Munich. In 1995 he was appointed full professor and director of the newly established Institute of Medical Physics at the Friedrich-Alexander-Universität Erlangen-Nürnberg, Germany. His main research interests are in the area of diagnostic imaging, the development and introduction of volumetric spiral CT being a particular focus. Other fields of research are radiation protection and the development of quantitative diagnostic procedures, e.g. for the assessment of osteoporosis, lung and cardiac diseases. His work is documented in more than 670 scientific papers with more than 160 original publications among these. He currently also holds appointments as Distinguished Visiting Professor at the Stanford University, Department of Radiology, and as Visiting Professor at the University of Wisconsin, Madison, Department of Medical Physics. He is a member of the International Commission on Radiation Units and Measurement (ICRU). He has organized and hosted numerous international workshops and conferences, among them the World Conference of Medical Physics in 2005.